

Iterated Networks and the Spectra of Renormalizable Electromechanical Systems

M. F. Barnsley,¹ T. D. Morley,¹ and E. R. Vrscay¹

Received October 12, 1984; revised January 18, 1985

Beginning with an *LRC* network with impedance function $Z(\omega)$, a sequence of iterated networks N_k with impedance functions $Z^{\circ k}(\omega)$, $k=1, 2, 3, \dots$, is introduced. The asymptotic comportment of $Z^{\circ k}(\omega)$ and the spectra of N_k are analyzed in terms of the Julia set of Z . An example is given of an iterated network associated with a cascade of period-doubling bifurcations.

KEY WORDS: Fractals; Julia set; iteration.

1. INTRODUCTION

This work was motivated in part by a paper of Domany, Alexander, Ben-simon, and Kadanoff⁽¹⁾ and some papers by Rammal⁽²⁻⁴⁾ concerning the distribution of eigenvalues of a renormalizable lattice model, based on a Sierpinski gasket, of interest in percolation theory; see also Ref. 5. It was shown that the eigenvalues accumulate on the Julia set of a polynomial, and, in Ref. 6, that the spectral density could be described in terms of condensed Julia sets. Similar observations, in the context of hierarchical lattice models in statistical physics, have been made by Derrida *et al.*⁽⁷⁾ Here we try to understand why these phenomena occur, and what is the most general framework.

The Sierpinski model can be viewed as a renormalizable mechanical system built of masses and springs. Since there is no resistance the eigenvalues are imaginary. We consider more general dissipative systems with complex spectra. Since most network theory is formulated for electrical

¹ School of Mathematics, Georgia Institute of Technology, Atlanta, Georgia 30332.

rather than mechanical systems, we work in terms of LRC networks; these have mechanical counterparts.⁽⁸⁾ Also, in line with much of the literature, we use driving terms of the form $e^{\omega t}$ rather than $e^{i\omega t}$, whence real resonances correspond to purely damped modes and pure imaginary resonances correspond to undamped oscillatory modes.

In part this study is an application of Julia set theory (see Ref. 9 for a review), which we use to describe the spectra of iterated networks. It may also add to Julia set theory by bringing to bear the physical intuitions that attach to the characteristics of electromechanical systems to the behavior of iterates of rational functions which map the right half-plane to itself.

In Section 2 we define the impedance function $Z(\omega)$ of an LRC network, recall its main properties, and show how it is calculated in terms of a Φ function. We also recall what is the dual of a planar network, and how to obtain *its* impedance.

In Section 3 we introduce iterated networks. One starts with a network, replaces each inductor by the whole network suitably scaled, replaces each capacitor by the dual network suitably scaled, and obtains the iterate of the original network. Its impedance function is $Z(Z(\omega))$. By repeating the process one obtains a sequence of networks $\{N_k\}$ associated with the sequence of functions $\{Z^{\circ k}(\omega): k = 1, 2, 3, \dots\}$.

In Section 4 we examine the asymptotic comportment of the impedances and spectra of the iterated networks N_k . With the aid of analysis by Fatou⁽¹⁰⁾ we completely describe what happens when $\deg Z = 1$, and when there is no resistance in the original network. Furthermore, we show quite generally that the spectra of the iterated networks approach condensed Julia sets, while, on the component of the complement of the Julia set which contains the right half-plane, their impedance functions converge to a constant, which implies a purely resistive behavior for the "limiting network." This may be deduced from the Wolff–Denjoy theorem concerning the iteration of analytic functions which map the right half-plane into itself.^(11–13)

In Section 5 we give an example of an iterated network involving a variable inductance $0 \leq L \leq 3 + 2\sqrt{2}$, whose characteristics undergo a succession of changes as L increases, associated with a cascade of period-doubling bifurcations which follows the now classical pattern.^(14–18) An approximation to such a network could actually be built, and might be the basis of a switching device capable of many different responses, orderly or chaotic. As expected from the work of Douady and Hubbard⁽¹⁹⁾ we find in parameter space a distorted Mandelbrot set.⁽²⁰⁾

2. THE IMPEDANCE FUNCTIONS OF *LRC* NETWORKS AND THEIR DUALS

Here we recall information about impedance functions which we use later. An *LRC* network is a collection of interconnected branches, consisting of inductors, resistors, and capacitors, together with two distinguished nodes labeled 0 and 1. If a current $e^{\omega t}$, where ω may be complex and t is time, is applied across the nodes then the resulting voltage drop can be written

$$Z(\omega) e^{\omega t}$$

where Z is a complex-valued function of ω . Z is the impedance function of the network.

Example 1. The impedance function for the *LRC* network in Fig. 1 is

$$Z(\omega) = \frac{LRC\omega^2 + L\omega}{LC\omega^2 + RC\omega + 1}$$

where L , R , and C are real nonnegative constants fixed by the inductance, resistance, and capacitance of the circuit.

Theorem 1 (see, for example, Ref. 21). The impedance function $Z(\omega)$ of an *LRC* network is a rational function of $\omega \in \mathbb{C}$. It obeys the following:

- (i) $Z(\omega)$ is real when ω is real;
- (ii) $Z(\bar{\omega}) = \overline{Z(\omega)}$, where the bar means complex conjugate;

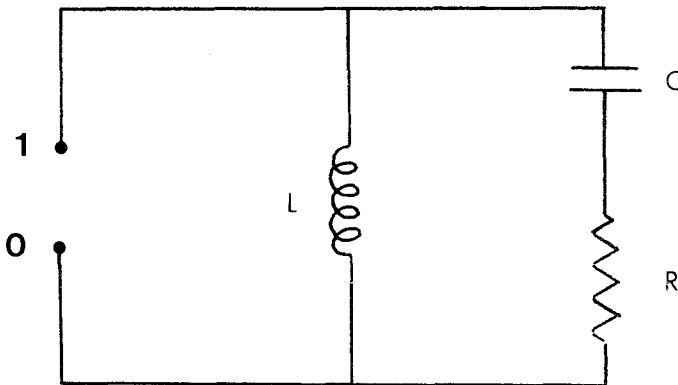

Fig. 1. The *LRC* network in Example 1.

- (iii) $\text{Re}(Z(\omega)) \geq 0$ whenever $\text{Re}(\omega) \geq 0$, where Re means the real part.

Conversely, any rational function $Z(\omega)$ with properties (i), (ii), and (iii) is the impedance function of some *LRC* network.

$Z(\omega)$ also has the following properties:

- (iv) $Z(\omega)$ has no poles where $\text{Re}(\omega) > 0$;
 (v) any pole on the imaginary axis is simple with positive residue;
 (vi) $1/Z(\omega)$ obeys (i), (ii), and (iii).

An *LRC* network is termed *planar* if the network together with a line from 0 to 1, can be drawn in the plane with no crossing lines. By the construction of Bott and Duffin,⁽²¹⁾ any *LRC* network is equivalent (in the sense that the two networks have the same impedance function) to a series-parallel *LRC* network, which is planar.⁽²²⁾ Thus, without loss of generality, we restrict attention to series-parallel *LRC* networks.

The impedance function may be calculated by direct solution of the system of ordinary differential equations which govern the circuit; these are obtained using Kirchoff's laws⁽²³⁾ and the constitutive equations

$$(a) \quad V = L \frac{dI}{dt}, \quad (b) \quad V = IR, \quad (c) \quad V = \frac{1}{C} \int_0^t I(s) ds$$

for the voltage drop V across an inductance L , resistance R , and capacitance C , respectively, when a current I flows through the component.

Equivalently, $Z(\omega)$ may be derived with the aid of Φ functions. Let each branch of a network be labeled with a different complex variable a, b, c, \dots ; and let $\Phi(a, b, c, \dots)$ be a rational function defined as follows. For a single-element network (see Fig. 2),

$$\Phi(a) = a$$

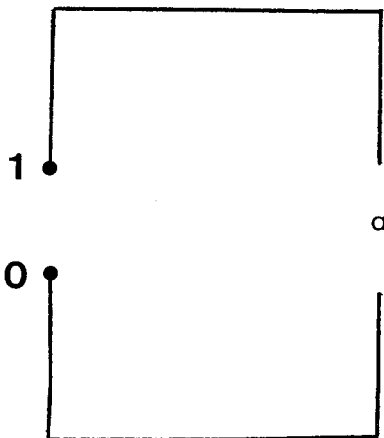

Fig. 2. A single-component network, whose branch is labeled a .

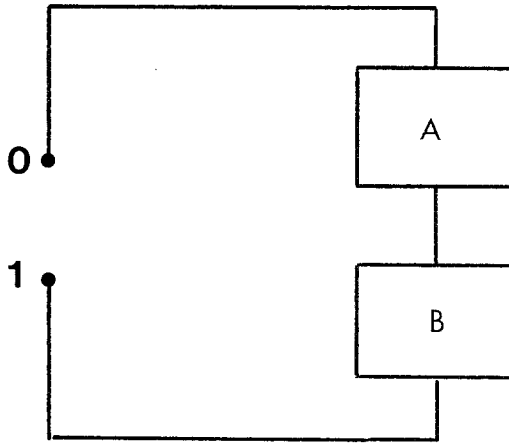

Fig. 3. Series connection of networks A and B .

For a network which is the series connection of two smaller networks A and B (see Fig. 3), whose Φ functions are Φ_A and Φ_B , we define

$$\Phi = \Phi_A + \Phi_B$$

Similarly, for a network which is the parallel connection of two smaller networks A and B (see Fig. 4), we define

$$\Phi = \Phi_A \Phi_B / (\Phi_A + \Phi_B)$$

Regardless of the order in which the network is considered to be composed of smaller networks, the resulting Φ function is the same.⁽²²⁾

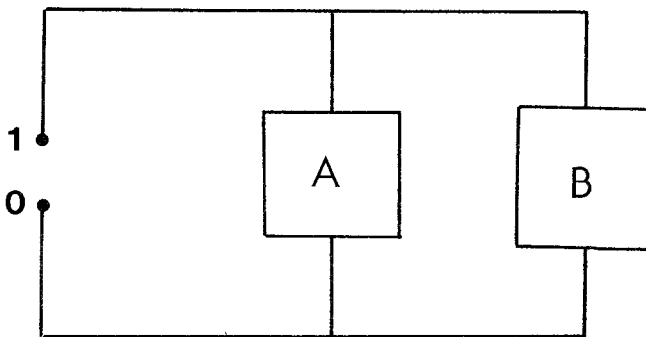

Fig. 4. Parallel connection of networks A and B .

Example 2. The Φ function for the labeled network in Fig. 5 is

$$\Phi(a, b, c) = \frac{a \cdot (b + c)}{a + b + c}$$

Theorem 2 (Ref. 22). The impedance function of a network whose Φ function is $\Phi(a, b, c, \dots)$ is

$$Z(\omega) = \Phi(Z_a(\omega), Z_b(\omega), Z_c(\omega), \dots)$$

where $Z_a(\omega) = L\omega$ if a corresponds to an inductance of L H, $Z_a(\omega) = R$ if a corresponds to a resistance of R Ω , and $Z_a(\omega) = 1/(C\omega)$ if a corresponds to a capacitance of C F. This expression is also true when a, b, c, \dots label smaller networks, interconnected to form the whole network, with impedances $Z_a(\omega), Z_b(\omega), Z_c(\omega), \dots$. The symbols H, Ω and F signify Henrys, Ohms and Farads respectively.

Example 3. The network in Fig. 6 may be labeled as in Fig. 5, where a corresponds to a smaller network A whose impedance is $Z_A(\omega)$. The impedance of the whole network obeys

$$Z(\omega) = \frac{Z_A(\omega)(1/C\omega + R)}{Z_A(\omega) + 1/C\omega + R}$$

The *dual* network of a planar network is constructed as follows.⁽²⁴⁾

- (i) Add the current source to the network.
- (ii) Place a node in each component of the complement (in the plane) of the network, including the unbounded component.
- (iii) For each inductor of L H in the original network, connect a

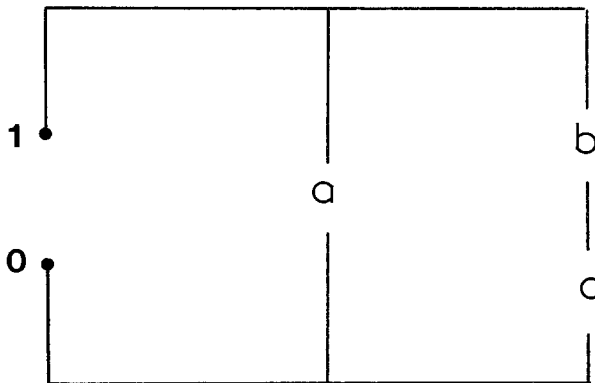

Fig. 5. The labeled network in Example 2.

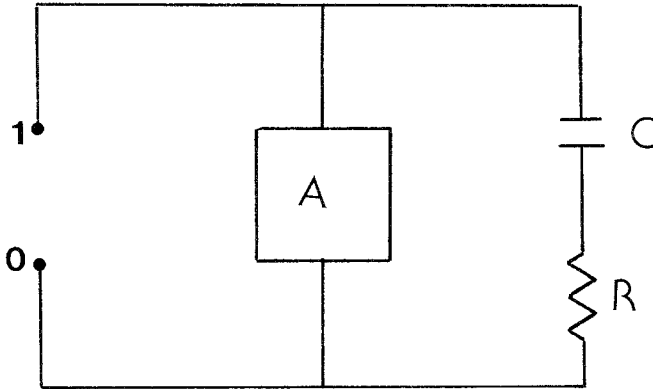

Fig. 6. The network in Example 3.

capacitor of $L F$ between the two nodes which lie in the two regions on whose common boundary the original inductor is situated.

(iv) For each resistor of $R \Omega$ in the original network, connect a resistor of $(1/R) \Omega$ between the two nodes which lie in the two regions on whose common boundary the original resistor is situated.

(v) For each capacitor of $C F$, connect an inductor of $C H$ between the two nodes which lie in the two regions on whose common boundary the original capacitor is situated.

(vi) The distinguished nodes labeled 0 and 1 in the new network are those which lie in the two regions on whose common boundary the original

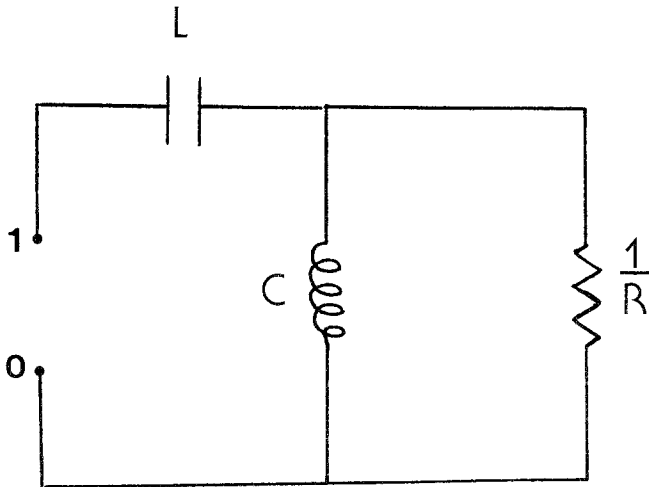

Fig. 7. The dual of the LRC network in Fig. 1.

current source is situated. The dual network of a planar *LRC* network is also a planar *LRC* network.

Example 4. The dual network of the network in Fig. 1 is shown in Fig. 7.

Theorem 3 (Ref. 22). Let $\Phi(a, b, c, \dots)$ be the Φ function for a planar *LRC* network of impedance $Z(\omega)$, and let $\Phi'(\alpha, \beta, \gamma, \dots)$ be the Φ function of the dual network, of impedance $Z'(\omega)$. Here α corresponds to a , β corresponds to b , and so on, as in the above construction. Then

$$[\Phi(a, b, c, \dots)]^{-1} = \Phi'(a^{-1}, b^{-1}, c^{-1}, \dots)$$

and $[Z(\omega)]^{-1} = Z'(\omega)$. More generally, if a, b, c, \dots label smaller networks, interconnected to form the whole network, with impedances $Z_a(\omega), Z_b(\omega), Z_c(\omega), \dots$, then

$$\begin{aligned} Z'(\omega) &= \Phi'(1/Z_a(\omega), 1/Z_b(\omega), 1/Z_c(\omega), \dots) \\ &= \Phi(Z_a(\omega), Z_b(\omega), Z_c(\omega), \dots)^{-1} = 1/Z(\omega) \end{aligned}$$

Example 5. The dual labeled network of the labeled network in Fig. 5 is shown in Fig. 8. The Φ functions for the two networks are

$$\Phi(a, b, c) = \frac{a \cdot (b + c)}{a + b + c} \quad \text{and} \quad \Phi'(\alpha, \beta, \gamma) = \alpha + \frac{\beta\gamma}{\beta + \gamma}$$

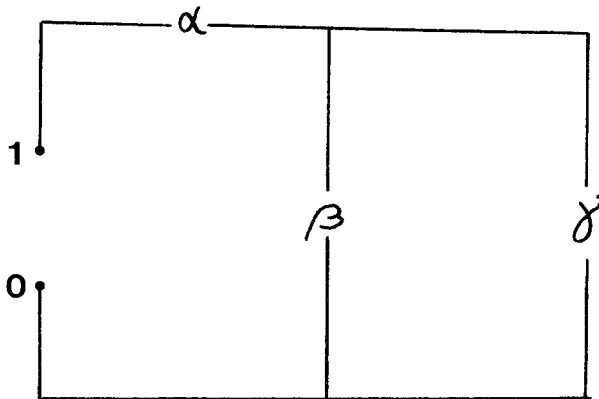

Fig. 8. The dual labeled network of the labeled network in Fig. 5.

3. ITERATED NETWORKS

In this section we introduce *iterated networks*. Given a planar *LRC* network N_1 with impedance function $Z(\omega)$, we construct a sequence of networks $\{N_k: k = 1, 2, 3, \dots\}$ such that the impedance function of N_k is $Z^{\circ k}(\omega)$, where

$$Z^{\circ 1}(\omega) = Z(\omega)$$

$$Z^{\circ(k+1)}(\omega) = Z^{\circ k}(Z(\omega)) \quad \text{for } k = 2, 3, \dots$$

N_{k+1} is constructed from N_k by performing simultaneously the following two steps. (i) Replace each inductor in N_k of L H by N_1 with all branch impedances multiplied by L . (ii) Replace each capacitor in N_k of C F by the dual network N'_1 , with all branch impedances multiplied by $1/C$. It is important to note that to multiply an impedance by a constant K means to multiply any inductance L and any resistance R by K and to divide any capacitance C by K .

Example 6. Let N_1 be the network in Fig. 1. Its dual N'_1 is shown in Fig. 7. Then N_2 is the network in Fig. 9, and N_3 is the network shown in Fig. 10.

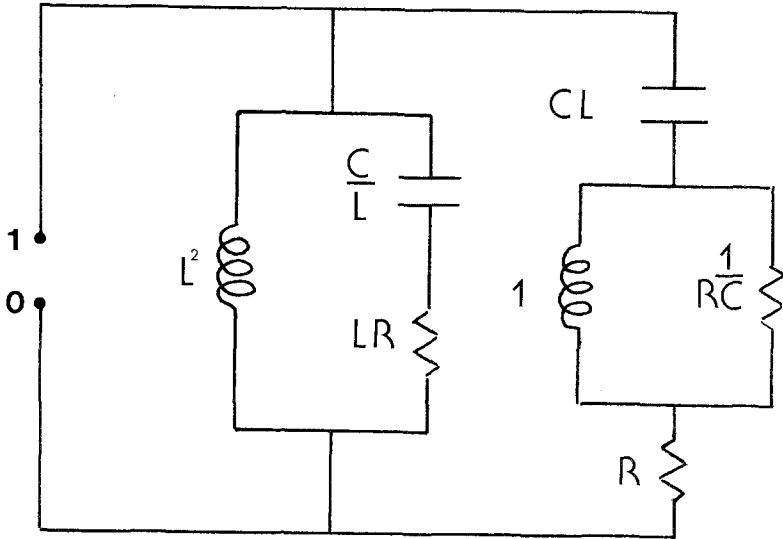

Fig. 9. The iterated network N_2 in Example 6.

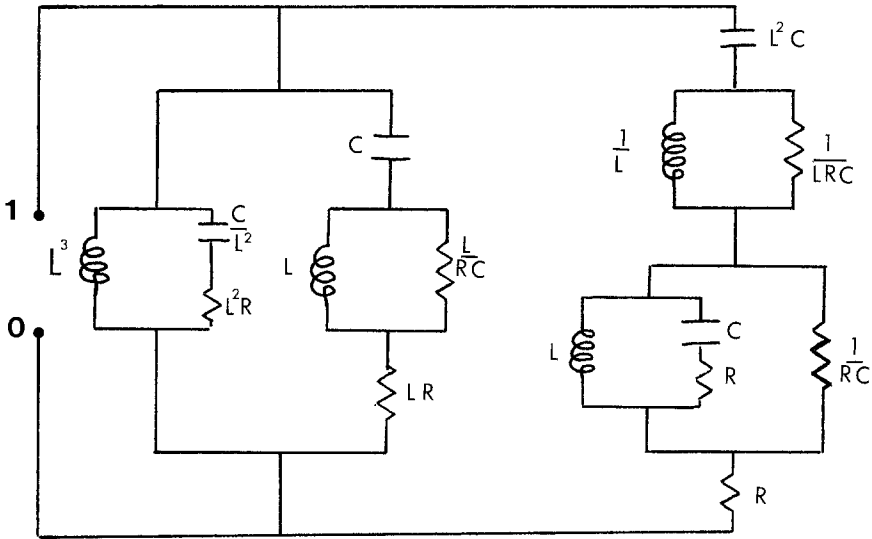

Fig. 10. The iterated network N_3 in Example 6.

Example 7. In Fig. 11 we show a sequence of iterated electrical networks, and a corresponding sequence of iterated mechanical networks, for an impedance function

$$Z(\omega) = \frac{LC\omega^2 + 1}{C\omega} \text{ (electrical)} = \frac{MC\omega^2 + 1}{C\omega} \text{ (mechanical)}$$

The schematics are the standard ones used by Olsen⁽⁸⁾: Motion of masses is rectilinear in the horizontal direction, and connecting double lines represent rigid levers allowed to rotate around the marked dots.

Theorem 4. The impedance function of N_k is $Z^{\circ k}(\omega)$.

Proof. The result is true for $k = 1$, so assume it is true for $k = 1, 2, 3, \dots, K$. Then the impedance function of N_k is

$$Z^{\circ K}(\omega) = \Phi \left(L_1\omega, L_2\omega, \dots, L_p\omega, R_1, R_2, \dots, R_q, \frac{1}{C_1\omega}, \frac{1}{C_2\omega}, \dots, \frac{1}{C_r\omega} \right)$$

where Φ is the Φ function for N_k . When we replace the inductors by N_1 and the capacitors by N'_1 as described above, we obtain the impedance of N_{k+1} to be

$$\Phi \left(L_1 Z(\omega), \dots, L_p Z(\omega), R_1, R_2, \dots, R_q, \frac{1}{C_1 Z(\omega)}, \dots, \frac{1}{C_r Z(\omega)} \right)$$

which is exactly $Z^{\circ(k+1)}(\omega)$.

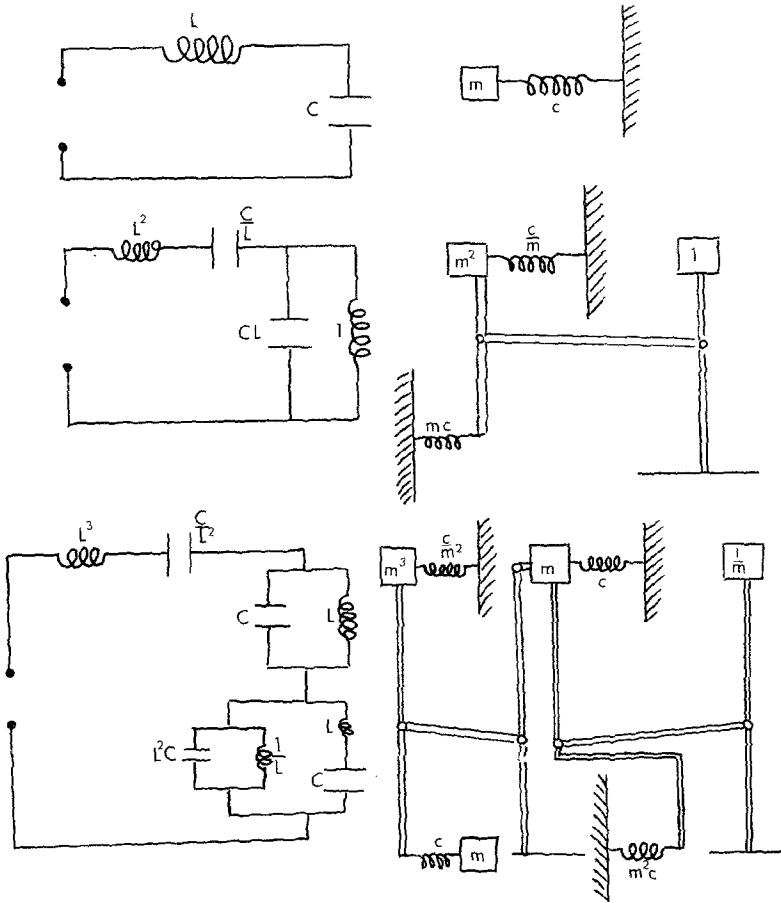

Fig. 11. A sequence of iterated electrical networks, and a corresponding sequence of iterated mechanical networks; see Example 7.

4. THE SPECTRA AND IMPEDANCE FUNCTIONS OF ITERATED NETWORKS

Let $Z(\omega)$ be the impedance function of an LRC network N_1 . We write $Z(\omega) = P(\omega)/Q(\omega)$, where P and Q are polynomials in ω , with no common factors. The degree of Z is

$$\text{deg } Z = \text{Max} \{ \text{deg } P, \text{deg } Q \}$$

The spectrum of N_1 is

$$\sigma(N_1) = \{ \omega \in \bar{\mathbb{C}} : Z(\omega) = \infty \}$$

where $\bar{\mathbb{C}} = \mathbb{C} \cup \{\infty\}$ denotes the Riemann sphere. In this section we study the behavior of the impedance functions $Z^{\circ k}(\omega)$ and the spectra $\sigma(N_k)$ of the iterated networks, when k becomes large.

Let $F: \bar{\mathbb{C}} \rightarrow \bar{\mathbb{C}}$ be a rational transformation. A k cycle of F is a set of k distinct points $\{z_i \in \bar{\mathbb{C}}: i = 1, 2, \dots, k\}$ such that

$$F(z_1) = z_2, \quad F(z_2) = z_3, \dots, F(z_k) = z_1$$

This k cycle is called attractive, indifferent, or repulsive according as the expansion factor $|(d/d\omega) F^{\circ k}(\omega)|_{\omega=z_i}$ is less than, equal to or greater than one, respectively. (If $z_1 = \infty$, use $\lim_{\omega \rightarrow \infty} \omega/F^{\circ k}(\omega)$ in place of the derivative.)

We introduce the following notation:

$$\mathcal{R} = \{z \in \mathbb{C}: \operatorname{Re} z \geq 0\} \cup \{\infty\}$$

$$\mathcal{R}^+ = \{z \in \mathbb{C}: \operatorname{Re} z > 0\}$$

$$\mathcal{L} = \{z \in \mathbb{C}: \operatorname{Re} z \leq 0\} \cup \{\infty\}$$

$$\mathcal{L}^- = \{z \in \mathbb{C}: \operatorname{Re} z < 0\}$$

Theorem 5. Let Z be the impedance function of an *LRC* network, with $\deg Z = 1$. Then the following are the only possibilities: (i) $Z(\omega) = \omega$; (ii) $Z(\omega) = C/\omega$, some $C \in (0, \infty)$; (iii) $Z(\omega)$ has exactly two fixed points $\omega_1 \in \mathcal{R}$ and $\omega_2 \in \mathcal{L}$, such that ω_1 is attractive and ω_2 is repulsive. The impedance functions $Z^{\circ k}(\omega)$ and the spectra $\sigma(N_k)$ of the iterated networks N_k behave as follows. In case (i), $N_k = N_1$ consists of a unit impedance, $Z^{\circ k}(\omega) = Z(\omega)$ and $\sigma(N_k) = \{\infty\}$ for all k . In case (ii), the even and odd sequences behave distinctly: the even sequence is the same as (i), and for the odd sequence $N_{2k+1} = N_1$ consists of capacitance C , $Z^{\circ(2k+1)}(\omega) = Z(\omega)$ and $\sigma(N_{2k+1}) = \{0\}$ for all k . In case (iii), $Z^{\circ k}(\omega)$ converges uniformly to ω_1 on compact subsets of $\bar{\mathbb{C}} \setminus \{\omega_2\}$; $Z^{\circ k}(\omega_2) = \omega_2$ for all k ; and either $\sigma(N_k)$ converges to ω_2 or $\sigma(N_k) = \{\omega_1\} = \{\infty\}$ for all k .

Proof. The positive-real properties of Z in Theorem 1 imply

$$Z(\omega) = \frac{a\omega + b}{c\omega + d} \neq \text{const}$$

where a, b, c, d are real nonnegative constants. Hence Z possesses two distinct real fixed points ω_1 and ω_2 . Let M be a Möbius transformation which maps ω_1 to the origin O and ω_2 to ∞ . Then

$$Z = M^{-1} \circ L \circ M$$

where for some $s \in \mathbb{C}$,

$$L(z) = sz$$

Since ω_1 is real and $s = Z'(\omega_1)$ it follows that s is real. If $s = +1$ then $Z(\omega) = M^{-1}(M(\omega)) = \omega$, and the case (i) behavior is readily verified. If $s = -1$ then $Z(\omega) = M^{-1}(-M(\omega)) = C/\omega$ for some $C \in (0, \infty)$, where one also uses the fact that $Z(\omega) = (a\omega + b)/(c\omega + d)$ with a, b, c, d real and nonnegative. The case (ii) behavior is readily verified.

If $|s| \neq 1$ then without loss of generality we can assume $|s| < 1$. Then O is an attractive 1-cycle for L , ∞ is a repulsive 1-cycle for L , and correspondingly ω_1 is an attractive 1-cycle for Z while ω_2 is a repulsive 1-cycle for Z . By symmetry $\omega_1, \omega_2 \in \mathbb{R} \cup \{\infty\}$, and since $Z(0) \geq 0$ we must have $\omega_1 \in \mathcal{R}$ and $\omega_2 \in \mathcal{L}$. The convergence of $Z^{\circ k}(\omega)$ to ω_1 on $\bar{\mathbb{C}} \setminus \omega_2$ follows at once from the convergence of $L^{\circ k}(\omega)$ to O on \mathbb{C} . Furthermore, the spectrum of N_k is the single point $\{Z^{\circ -k}(\infty)\} = \{\omega \in \bar{\mathbb{C}}: Z^{\circ k}(\omega) = \infty\}$, which implies the final statement in the theorem. ■

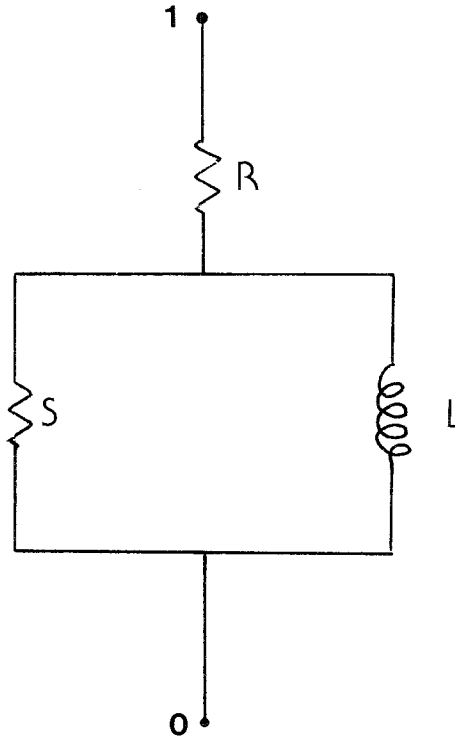

Fig. 12. The LR network in Example 8.

Example 8. Let N_1 be the LR network in Fig. 12, with impedance function

$$Z(\omega) = R + \frac{LS\omega}{S + L\omega}$$

where L , R , and S are positive constants. The fixed points are

$$\begin{aligned} \text{(attractive)} \quad \omega_1 &= -\frac{1}{2} \left(\frac{S}{L} - R - S \right) + \frac{1}{2} \left[\left(\frac{S}{L} - R - S \right)^2 + \frac{4RS}{L} \right]^{1/2} \\ \text{(repulsive)} \quad \omega_2 &= -\frac{1}{2} \left(\frac{S}{L} - R - S \right) - \frac{1}{2} \left[\left(\frac{S}{L} - R - S \right)^2 + \frac{4RS}{L} \right]^{1/2} \end{aligned}$$

Notice that $\omega_1 > 0$ and $\omega_2 < 0$. The iterated network N_k is represented schematically in Fig. 13. Its impedance function approaches the value ω_1 for all input frequencies except ω_2 , at which the impedance is ω_2 . The spectrum of N_k approaches $\{\omega_2\}$. It is as though the network N_k forgets the single impedance element L^k which it contains, in the infinite limit, except at one special driving frequency. The iteration provides a continued fraction representation of ω_1 .

The situation for $\deg Z = 1$ will be seen to be echoed and beautifully elaborated in the case $\deg Z > 1$: sequences of iterated networks in the hyperbolic case have spectra which converge to the Julia set of $Z(\omega)$, while sequences of impedance functions $\{Z^{\circ k}(\omega)\}$ typically have subsequences which converge to piecewise constant functions.

The Julia set $J(F)$ of a rational map $F: \bar{\mathbb{C}} \rightarrow \bar{\mathbb{C}}$ of degree greater than one is the closure of $\{\text{all repulsive } k \text{ cycles of } F: k = 1, 2, 3, \dots\}$.⁽²⁵⁾ Its complement $\bar{\mathbb{C}} \setminus J(F)$, which we call the Fatou set of F , is such that the sequence of iterated functions $\{F^{\circ k}(z)\}$ is equicontinuous, in the spherical metric, on some neighborhood of each point of $\bar{\mathbb{C}} \setminus J(F)$ (see Ref. 9, for example). $J(F)$ is a compact nondenumerable subset of $\bar{\mathbb{C}}$, and if it is not equal to $\bar{\mathbb{C}}$ then it contains no open subsets of $\bar{\mathbb{C}}$ —that is, it has no interior. In general the Hausdorff–Besicovitch dimension of $J(F)$ is noninteger, whence $J(F)$ is a fractal as defined by Mandelbrot.⁽²⁶⁾

Theorem 6. Let $Z(\omega)$ be the impedance function of an LRC network, with $\deg Z \geq 2$. Then $J(Z) \subset \mathcal{L}$.

Proof. Suppose there is $z_0 \in J(Z)$ with $\operatorname{Re} z_0 > 0$. Let U be an open neighborhood of z_0 , with $\operatorname{Re} z > 0$ for all $z \in U$. Let C be any closed set in $\{z \in \bar{\mathbb{C}}: \operatorname{Re} z \leq 0\} \setminus \operatorname{Exc}(Z)$, where $\operatorname{Exc}(Z)$ is the set of exceptional points of Z and contains at most two points. Then by Brolin,⁽²⁷⁾ Theorem 4.2, there

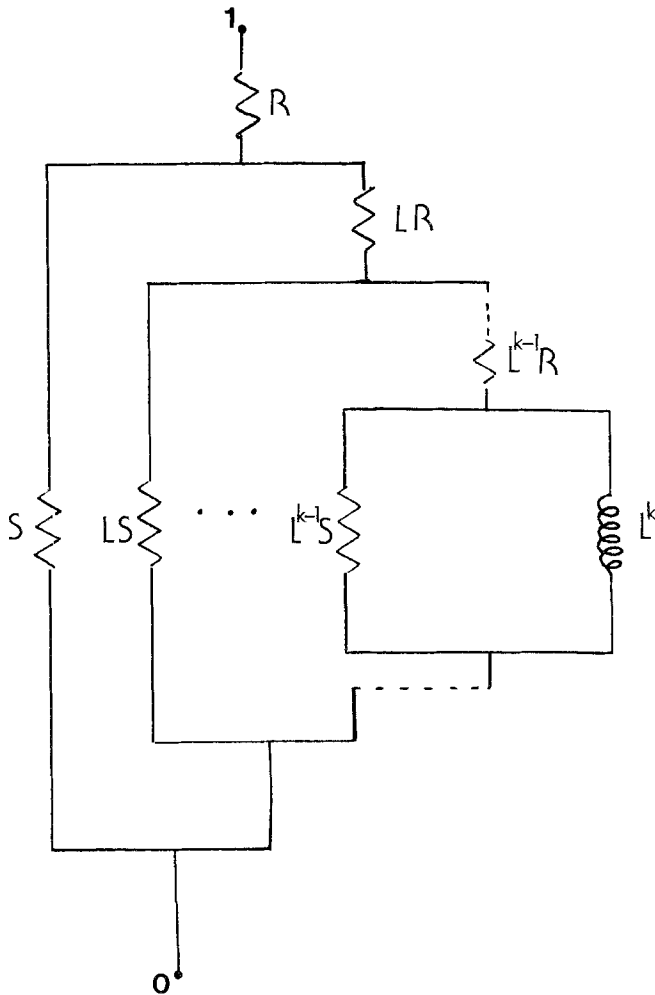

Fig. 13. Schematic representation of the iterated LR network N_k in Example 8.

exists a finite positive integer n such that $C \subset Z^{o^n}(U)$. This is impossible because Z maps the right half-plane into itself. ■

To analyze $\{Z^{o^k}\}$ one may use the Wolff–Denjoy theorem^(11–13) concerning the iteration of analytic functions which map \mathcal{R}^+ into itself. This yields quite straightforwardly $\lim_{k \rightarrow \infty} Z^{o^k}(\omega) = \omega_1 \in [0, \infty]$ for all $\omega \in \mathcal{R}^+$. However, more information is provided by Sullivan’s classification which we briefly summarize next.

A theorem of Sullivan^(28,29) states that every component D of the Fatou set is eventually periodic under F . That is, there exist positive

integers m and k such that $S = F^{\circ m}(D) = F^{\circ(m+k)}(D)$. The period is the smallest k such that this is true. Furthermore, Sullivan has completely classified the possibilities for the action of $F^{\circ k}(z)$ on S .

(i) *Hyperbolic Case*: For all $z \in S$,

$$\lim_{n \rightarrow \infty} F^{\circ nk + j - 1}(z) = z_j \quad \text{for } j = 1, 2, \dots, k,$$

where $\{z_j \in F^{\circ(j-1)}(S) : j = 1, 2, \dots, k\}$ is an attractive k cycle of F .

(ii) *Parabolic Case*: Same as (i) except that the k cycle is indifferent with

$$(F^{\circ k})'(z_1) = 1$$

and $\{z_1, z_2, \dots, z_k\} \subset J(F)$.

(iii) *Rotation Domain Case*: $F^{\circ k}$ acting on S is analytically conjugate either to an irrational rotation of the unit open disk, in which case S is called a Siegel disk, or to an irrational rotation of an open annulus, in which case S is called a Herman ring.

In cases (i) and (ii) there is a critical point of F in $\bigcup_{j=1}^k F^{\circ(j-1)}(S)$. In case (iii) the boundary of S is contained in the closure of the set of all forward images under iterates of F of the set of critical points of F .

The exceptional set of a rational transformation $F: \bar{\mathbb{C}} \rightarrow \bar{\mathbb{C}}$ of degree greater than one is

$$\text{Exc}(F) = \{\omega \in \bar{\mathbb{C}} : F^{\circ -1}(\omega) = \omega\}$$

where $F^{\circ -1}(\omega) = \{s \in \bar{\mathbb{C}} : F(s) = \omega\}$. F possesses at most two exceptional points.⁽²⁷⁾

Let $\{S_n : n = 1, 2, 3, \dots\}$ be a sequence of subsets of $\bar{\mathbb{C}}$. Then by $\lim_{n \rightarrow \infty} S_n$ we mean the set of points $z \in \bar{\mathbb{C}}$ such that whenever \mathcal{N} is a neighborhood of z ,

$$\mathcal{N} \cap S_n \neq \emptyset \quad \text{for infinitely many } n$$

The following theorem tells how the sequence of impedance functions $\{Z^{\circ k}(\omega)\}$ for the iterated networks N_k converge to a real constant for all ω in a domain bounded by the Julia set of Z . It also states that, in general, their spectra $\sigma(N_k)$ converge to the Julia set $Z(\omega)$.

Theorem 7. Let $Z(\omega)$ be the impedance function of an *LRC* network N_1 , with $\deg Z \geq 2$. Let P denote the component of the Fatou set of Z which contains \mathcal{R}^+ . Then

$$Z(P) = P$$

and the action of Z on P is either hyperbolic or parabolic. There is a fixed point $0 \leq \omega_1 \leq \infty$ such that

$$\lim_{k \rightarrow \infty} Z^{\circ k}(\omega) = \omega_1 \quad \text{for all } \omega \in P$$

If $0 < \omega_1 < \infty$ then the action of Z on P is hyperbolic. If $\omega_1 \in \{0, \infty\}$ then either $0 < Z'(\omega_1) < 1$ or $Z'(\omega_1) = 1$ and $\omega_1 \in J(Z)$.

If $\infty \notin \text{Exc}(Z)$ then

$$\lim_{k \rightarrow \infty} \sigma(N_k) \supseteq J(Z)$$

with equality when $\infty \cap \lim_{k \rightarrow \infty} Z^{\circ k}(\omega) = \emptyset$ for all $\omega \in \bar{\mathbb{C}} \setminus J(Z)$.

Proof. That $Z(P) = P$ follows from the fact that P must be eventually periodic together with $Z(\mathcal{R}) \subset \mathcal{R}$. Suppose P is a rotation domain. Then $Z(\mathcal{R}^+) \subset \mathcal{R}^+$ implies $P = \mathcal{R}^+$. \mathcal{R}^+ is not topologically conjugate to an annulus, so P is not a Herman ring. It is not a Seigel disk because then it would have a fixed point $\omega_1 \in (0, \infty)$ with $Z'(\omega_1) = e^{2\pi i\theta}$, and θ irrational, which is not possible as $Z'(\omega_1)$ is real. Hence the action of Z on P is hyperbolic or parabolic. The corresponding fixed point ω_1 is real by symmetry, and obeys $0 \leq \omega_1 \leq \infty$.

If $0 < \omega_1 < \infty$ then $\omega_1 \notin J(Z)$, so Z on P must be hyperbolic. If $\omega_1 = 0$ then $0 < Z'(\omega) \leq 1$, since if $\omega_1 \leq 0$ then by considering the Taylor series expansion of Z about O we find a set $\mathcal{N} \cap \mathcal{R}^+$, where \mathcal{N} is a neighborhood of O , which is mapped into \mathcal{L}^- under Z . The parabolic case occurs when $Z'(\omega_1) = 1$, and then $\omega_1 \in J(z)$. The possibility that $\omega_1 = \infty$ is analyzed in the same way, by considering $1/Z(1/\omega)$ in place of $Z(\omega)$.

The last part of the theorem follows from Brodin,⁽²⁷⁾ Theorem 6.1 and Lemma 6.3, on noting that $\sigma(\mathcal{N}_k)$ is just the set of k th-order predecessors of ∞ under Z , namely,

$$\sigma(\mathcal{N}_k) = Z^{\circ -k}(\infty) = Z^{\circ (-k+1)}(\sigma(N_1)) \quad \blacksquare$$

Example 9. The impedance function for the *LRC* network in Fig. 1, with $R = C = 1$, is

$$Z(\omega) = \frac{L\omega^2 + L\omega}{L\omega^2 + \omega + 1}$$

It has the fixed points

$$\omega_1 = \frac{1}{2L} \{L - 1 + [(L - 1)(5L - 1)]^{1/2}\}$$

$$\omega_2 = \frac{1}{2L} \{L - 1 - [(L - 1)(5L - 1)]^{1/2}\}$$

$$\omega_3 = 0$$

For $L > 1$ we find $\omega_1 \in \mathcal{R}^+$ is attractive with

$$Z'(\omega_1) = \frac{1}{L} - \frac{\omega_1^2}{(1 + \omega_1)^2}$$

while ω_3 is repulsive with $Z'(\omega_3) = L$. As $L \rightarrow 1$, ω_2 and ω_1 tend to coalescence with ω_3 , producing a rationally indifferent fixed point at 0. For $L \geq 1$, $\omega_3 \in J(Z)$, but when $0 < L < 1$, ω_3 becomes attractive and separated from the Julia set.

For all $0 < L < \infty$, ∞ is a repulsive fixed point of $Z(\omega)$. Hence by Theorem 7, $\sigma(N_k)$ converges to $J(Z)$ as $k \rightarrow \infty$.

Finally, we consider iterated LC networks—networks which contain no resistors. Their impedance functions, in addition to obeying Theorem 1, have the property that they map the imaginary axis into itself, and thus can always be written

$$Z(\omega) = \frac{A_0}{\omega} + K\omega + \sum_{k=1}^m \frac{A_k \omega}{\omega^2 + a_k^2}$$

where $a_k > 0$, $A_k > 0$ for $k = 1, 2, \dots, m$, $A_0 \geq 0$ and $K \geq 0$. We assume $\deg Z \geq 2$. Thus, $Z(\omega)$ has simple poles with positive residues, in complex conjugate pairs on the imaginary axis.

Following Fatou,⁽¹⁰⁾ Chap. III, p. 225 *et seq.*, one can make a complete analysis of the LC case. Let F be a rational transformation with $\deg F \geq 2$, such that $F(\mathcal{R}) = \mathcal{R}$ and $F(I) = I$, where I denotes the imaginary axis. Then $J(F) \subset I$ and one of the following possibilities holds:

- (i) F possesses two attractive fixed points $\omega_1 \in \mathcal{R}^+$ and $\omega_2 \in \mathcal{L}^-$, mirror images of one another in I ;
- (ii) F possesses a single attractive fixed point $\omega_1 \in I$;
- (iii) F possesses a single indifferent fixed point of multiplicity two or three.

Using this analysis together with the fact that for an LC network $Z: \mathbb{R} \rightarrow \mathbb{R}$, we obtain the following:

Theorem 8. Let $Z(\omega)$ be the impedance function for an LC network N_1 , with $\deg Z \geq 2$. Let P be the component of $\mathbb{C} \setminus J(Z)$ which contains \mathcal{R}^+ . Then one of the following holds:

- (i) $Z(\omega)$ possesses an attractive fixed point $0 < \omega_1 < \infty$, $J(Z) = I$, and $P = \mathcal{R}^+$.

- (ii) Either 0 or ∞ is an attractive fixed point, in which case $J(Z) = \mathcal{C}$ is a Cantor set in I and $P = \mathbb{C} \setminus \mathcal{C}$.
- (iii) Either 0 or ∞ is an indifferent fixed point of multiplicity three, $J(Z) = I$, and $P = J \setminus I$.

To avoid many definitions and special cases, the following discussion to the end of this section is somewhat heuristic.

The spectrum of an *LRC* network N_k is the set of eigenvalues of an associated matrix M_k determined by the combinatorial structure of N_k and by the numerical values of its inductors, resistors, and capacitors. If the structure is such that $\{N_k\}_{k=1}^\infty$ (or a suitable subsequence) converges to a limiting network N_∞ , then N_∞ displays a renormalization property. On replacing all of the inductors and capacitors in N_∞ by N_1 and its dual, as described above, one obtains N_∞ back again. The limiting matrix operator M_∞ , if it exists, will also be renormalizable. Since M_∞ contains all observable information about the characteristics of N_∞ we think of it as the Hamiltonian of the system; this is consistent with the work of Rammal⁽³⁾ and Kadanoff.⁽¹⁾

Under the assumptions of the last paragraph we show that the density of states for M_∞ is often the balanced measure⁽³⁰⁻³²⁾ for $Z(\omega)$. Suppose $\infty \cap \lim Z^{\circ k}(\omega) = \emptyset$ for all $\omega \in \mathbb{C} \setminus J(Z)$. Then the eigenvalues of M_k , of which there are $(\deg Z)^k$ counting multiplicities, are just $\{Z^{\circ -k}(\infty)\}$ and the corresponding density of states is the measure $\mu^{(k)}$ which attaches weight $(\deg Z)^{-k}$ to each eigenvalue. It follows from Ref. 33 (see also Ref. 34) that $\mu^{(k)} \rightarrow \mu$ weakly, where μ is the balanced measure for $Z(\omega)$. Recall that the support of μ is $J(Z)$, that μ admits no point masses and that

$$\mu(B) = \frac{1}{\deg Z} \sum_{i=1}^{\deg Z} \mu[Z_i^{-1}(B)]$$

for all Borel subsets B of \mathbb{C} , where $\{Z_i^{-1}: i = 1, 2, \dots, \deg Z\}$ is a complete assignment of branches of the inverse of Z . In such cases M_∞ possesses no discrete eigenvalues. A similar situation occurs when

$$\infty \cap \lim_{k \rightarrow \infty} Z^{\circ k}(\omega) \neq \emptyset$$

except that condensed balanced measures and discrete eigenvalues are obtained; cf. Ref. 6. These measures attach mass to a denumerable set of points, the preimages under Z of ∞ , whose set of accumulation points is $J(Z)$. In such cases $J(Z)$ carries none of the spectral mass. As an example, the renormalizable network of Rammal, referred to above, is associated with a condensed balanced measure which has been extensively studied.

Other renormalizable networks whose spectra are typically condensed Julia sets can be constructed starting from an initial pair of networks N_1 and \tilde{N}_1 , with impedance functions Z and \tilde{Z} , respectively. The k th network \tilde{N}_k is gotten from N_{k-1} by replacing each inductor of N_{k-1} by \tilde{N}_1 , scaled by the corresponding inductance, and replacing each capacitor of N_k by the dual \tilde{N}'_1 , scaled by the corresponding capacitance. The impedance function \tilde{Z}_k of \tilde{N}_k is clearly

$$\tilde{Z}_k(\omega) = Z^{\circ(k-1)} \circ \tilde{Z}(\omega)$$

When $\tilde{N}_1 = N_1$, we have $\tilde{Z}_k(\omega) = Z^{\circ k}(\omega)$ and the previous situation is regained. Suppose that the matrix operator \tilde{M}_k corresponding to \tilde{N}_k converges to an operator \tilde{M}_∞ , and \tilde{N}_k converges to \tilde{N}_∞ as $k \rightarrow \infty$. Then \tilde{N}_∞ is renormalizable in an obvious manner and, if ∞ is a fixed point of Z , the associated density of states will be a condensed balanced measure generated by $Z(\omega)$ with condensation points equal to the pole locations of $\tilde{Z}(\omega)$.

The spectrum of such a renormalizable network can be formulated as the attractor of an iterated function system (IFS) of the form $\{\bar{\mathbb{C}}, w_1(z)\}$:

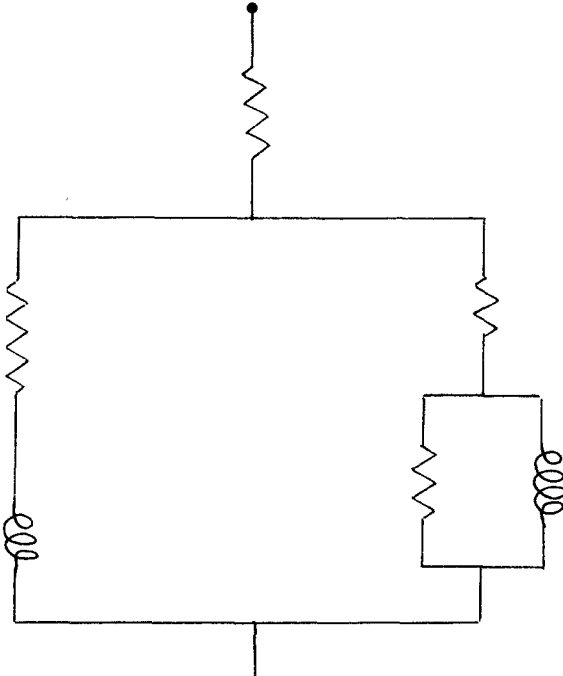

Fig. 14. The LR network N_1 in Example 10.

$i = 1, 2, \dots, \deg Z\}$, with condensation set L equal to the pole locations of Z ; see Ref. 35 for example. A remarkable fact is that, in a certain sense, N_∞ is itself an attractor of an IFS. We explain this with an example.

Example 10. Consider the LR network in Fig. 14, where $L = R = 1$. One way to represent N_k for large k is to successively nest the elements, using smaller and smaller symbols for the components, as suggested in Fig. 15. The limiting picture thus obtained is the attractor for the following IFS with condensation, (see Ref. 35 for terminology):

$$\{\square, w_1(x, y), w_2(x, y), L\}$$

where \square is the unit square in $\mathbb{R} \times \mathbb{R}$ and L is the point set drawn with solid lines in Fig. 16. $w_1(x, y)$ is the affine map which takes \square onto $\square_{\#1}$ and $w_2(x, y)$ is the affine map which takes \square onto $\square_{\#2}$. By a theorem of Ref. 35 the unique attractor for the IFS is the desired drawing.

Now surprisingly, the mechanical model of Rammal can similarly be described, since the Sierpinski triangle is the attractor for an IFS. What interests us deeply for the future is the interplay between the combinatorial

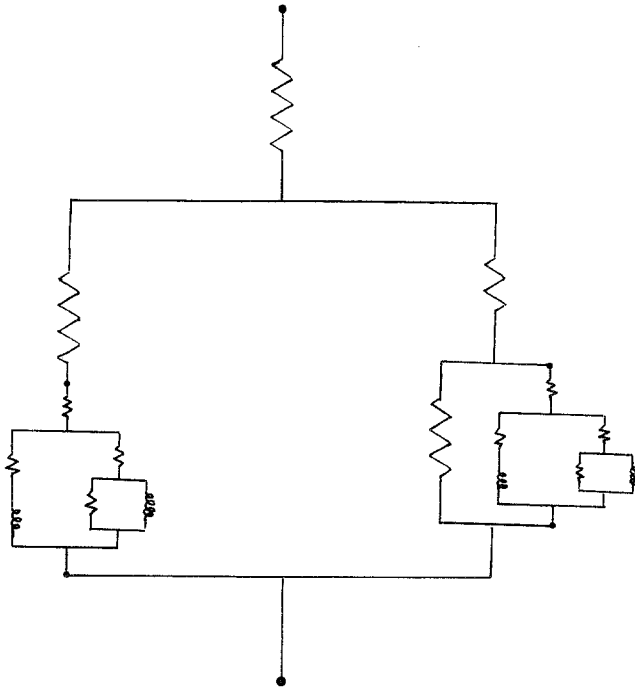

Fig. 15. Representation of N_2 using successively nested smaller components, for N_1 in Fig. 14.

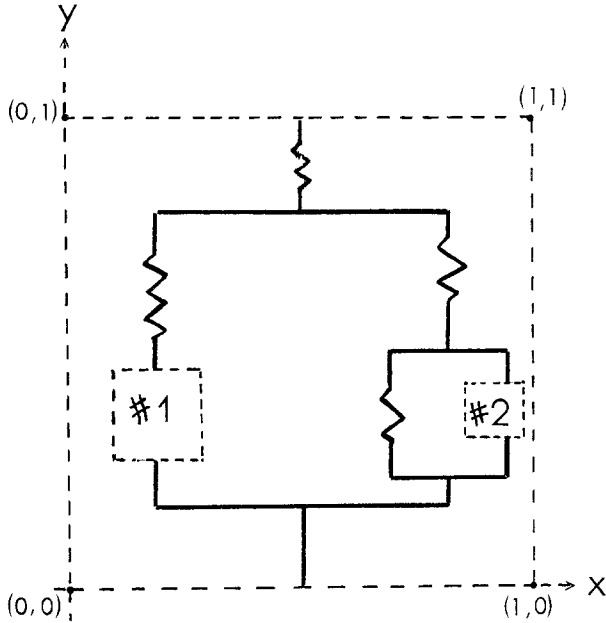

Fig. 16. Diagram used to represent N_∞ as an attractor for an IFS with condensation. The condensation set L is drawn with solid lines.

and geometrical structure for the IFS which describes a renormalizable system, and that of the IFS which gives its spectrum.

5. A PERIOD-DOUBLING CASCADE

In Section 4, we say that $\{Z^{\circ k}(\omega)\}_{k=1}^\infty$ behaves in an orderly manner on P , the component of $\bar{\mathbb{C}} \setminus J(Z)$ which contains the open right half-plane. Indeed $Z^{\circ k}(\omega) \rightarrow \text{const}$ uniformly on closed subsets of P . Here we show that the behavior of $\{Z^{\circ k}(\omega)\}_{k=1}^\infty$ on $\bar{\mathbb{C}} \setminus [J(Z) \cup P]$ can be very complicated. We do this with an example of an iterated network whose characteristics display, as the inductance parameter L is varied, a succession of changes which follows the now classical pattern, studied by Myrberg,⁽¹⁵⁾ May,⁽¹⁴⁾ Milnor and Thurston,⁽¹⁶⁾ Feigenbaum,⁽¹⁸⁾ and others,^(36,39) for iterated one-parameter families of unimodular functions typified by $f_\lambda(z) = z^2 - \lambda$ for $\lambda \in [0, 2]$.

We consider iterates of the network in Fig. 1, with $R = C = 1$ and variable inductance L . The impedance function is

$$Z(\omega) = \frac{L\omega^2 + L\omega}{L\omega^2 + \omega + 1}$$

In Example 9 we examined the action of Z on P . The critical points are

$$c_1 = \frac{L}{2L^{1/2} - 1} \quad \text{and} \quad c_2 = \frac{-L}{2L^{1/2} + 1}$$

Here we are concerned with what happens when $L > 1$. c_1 lies in the basin of attraction of the attractive fixed point $\omega_1 \in \mathcal{R}$ while c_2 has a diversity of eventual behaviors, depending on the value of L . For $1 < L < \lambda_1 = 2.707\dots$, c_2 is drawn to an attractive real 1-cycle ω_2 lying in \mathcal{L}^- . The basin of attraction for this cycle is bounded by a simple Jordan curve, and is illustrated in Figs. 17, 18, and 19, corresponding to $L = 1.5, 2,$ and 2.5 , respectively. The innermost region represents points which take less than six iterations to arrive within 0.05 of ω_2 (represented by \bullet), the next darker annular region represents points which take from six to nine iterations to arrive within 0.05 of ω_2 , while the darkest region represents points which require ten or more iterations. The outer boundary represents $J(Z)$, and the exterior region represents points which lie in P . As L increases toward $2.707\dots$, $J(Z)$ starts to pinch together at a countable infinity of pairs of points, just as happens for the Julia set of $z^2 - \lambda$ as $\lambda \in \mathbb{R}$ approaches 0.75^- .⁽³⁷⁾ When $L = 2.707\dots$ the pinching is complete, ω_2 is rationally indifferent and has joined $J(Z)$ at a pinch point which is on the

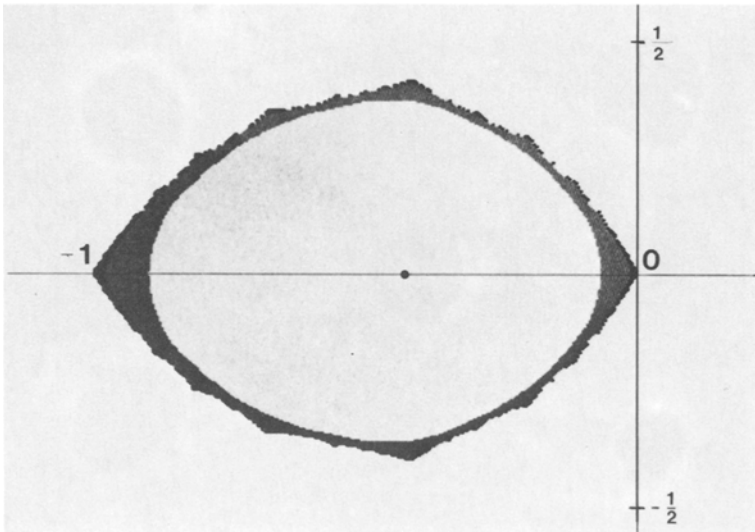

Fig. 17. The Julia set for $(L\omega^2 + L\omega)/(L\omega^2 + \omega + 1)$ with $L = 1.5$; see text.

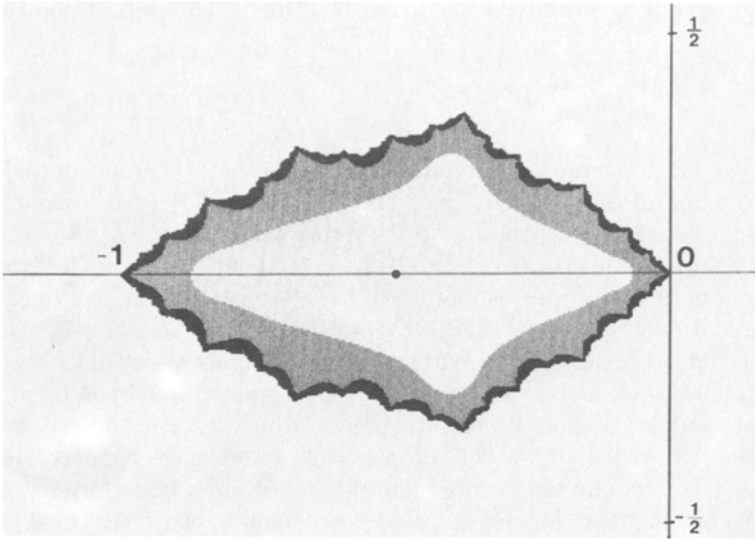

Fig. 18. The Julia set for $(L\omega^2 + L\omega)/(L\omega^2 + \omega + 1)$ with $L=2$.

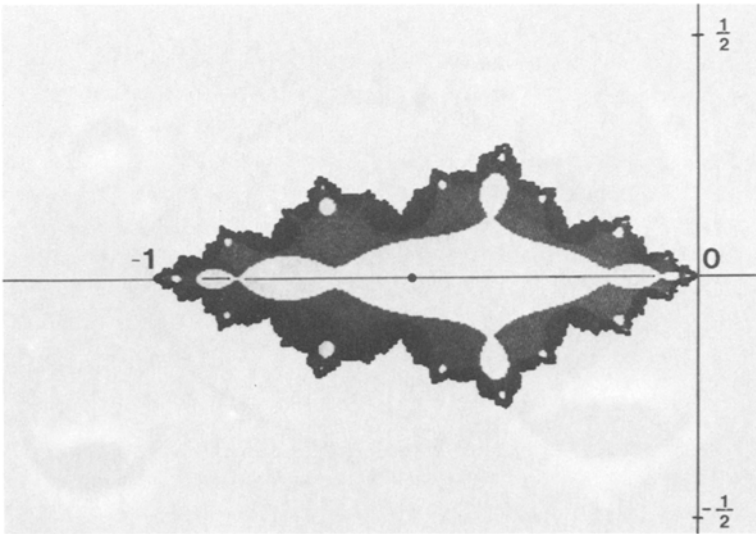

Fig. 19. The Julia set for $(L\omega^2 + L\omega)/(L\omega^2 + \omega + 1)$ with $L=2.5$.

verge of giving birth to an attractive real 2-cycle. For $2.707 \cdots < L < 3.823 = \lambda_2$, c_2 is drawn to an attractive real 2-cycle lying in \mathcal{L}^- , as illustrated in Fig. 20 for $L = 3$. $J(Z)$ is now bubbly, and the interior of each bubble is drawn under $Z^{\circ k}$, some k , into the 2-cycle of domains which contains the 2-cycle. Figures 21 and 22 show successive magnifications of part of Fig. 20, illustrating the fractal character of $J(Z)$. For $3.823 \cdots < L < 4.142 \cdots = \lambda_3$, the complement of $J(Z) \cup P$ is associated with an attractive real 4-cycle, derived from the 2-cycle by pitchfork bifurcation; while for $4.142 \cdots < L < 4.214 = \lambda_4$ it is associated with a real 8-cycle, ... and so on. This first cascade of period-doubling bifurcations is completed before $L = 4.5$. The sequence of successive ratios $(\lambda_{n-1} - \lambda_n)/(\lambda_n - \lambda_{n+1})$ approaches the Feigenbaum number 4.669..., as $n \rightarrow \infty$.

For $0 \leq L \leq 3 + 2\sqrt{2}$, $Z(\omega)$ maps the interval $[-1, 0]$ into itself, advancing as L increases from a map which takes the whole interval to a single point to one which takes the interval 2:1 onto itself. Since $Z(\omega)$ is rational, it has negative Schwartzian derivative,⁽³⁸⁾ and thus we have a one-parameter family of unimodular functions obeying the conditions used by Collet and Eckmann.⁽³⁶⁾

One may also consider the comportment of $\{Z^{\circ k}(\omega)\}$ for complex values of L in a neighborhood of $[0, 6]$. Figure 23 provides a parameter space description; it was obtained as follows. For each pixel in a

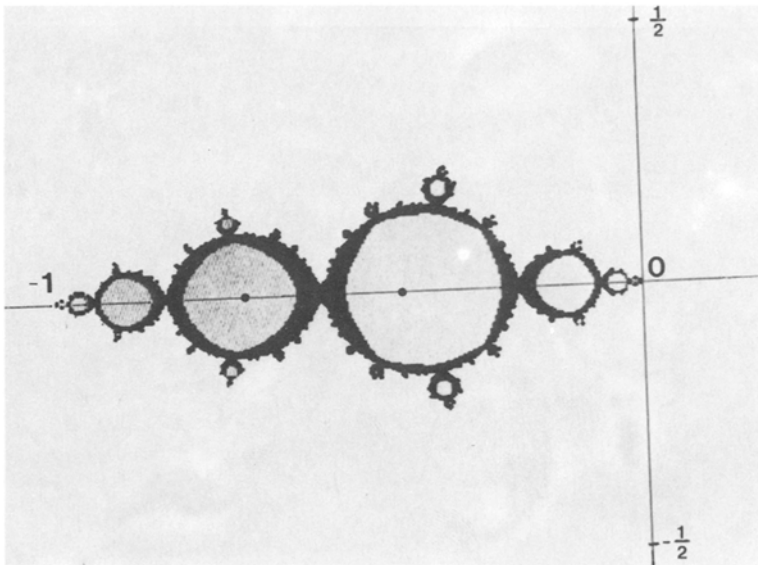

Fig. 20. The Julia set for $(L\omega^2 + L\omega)/(L\omega^2 + \omega + 1)$ with $L = 3$.

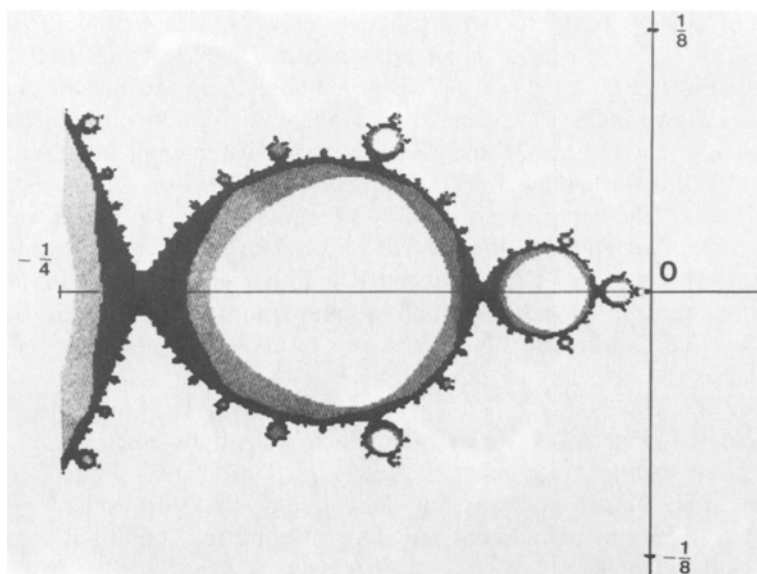

Fig. 21. Blowup of part of Fig. 20.

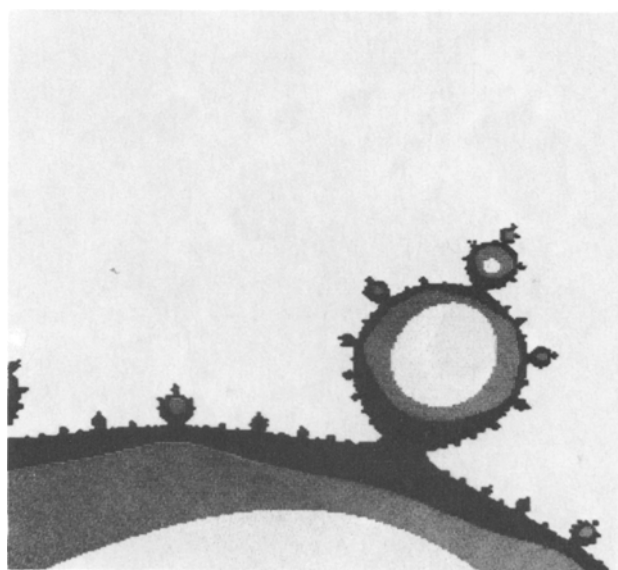

Fig. 22. Magnification of a bubble in Fig. 21.

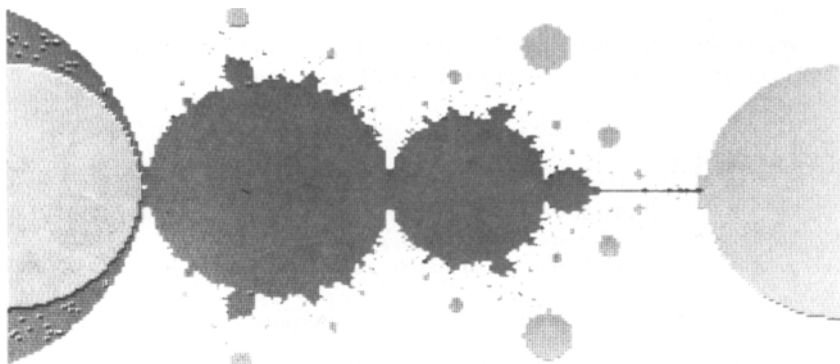

Fig. 23. Parameter space map of Julia sets for $(L\omega^2 + L\omega)/(L\omega^2 + \omega + 1)$; see text. It contains a distorted portion of the Mandelbrot set for $z^2 - \lambda$.

240 × 240 grid, representing $L \in [0, 6] \times [-3i, 3i]$, $Z^{\circ 50}(c_2)$ was computed. If the result lay within 0.1 of O then the pixel was colored grey, if it lay within 0.1 of the fixed point in \mathcal{R}^+ it was colored black, and otherwise it was colored white.

Figure 23 appears to contain a distorted portion of the Mandelbrot set for $z^2 - \lambda$. This suggests that, in the terminology of Ref. 19, $Z(\omega)$ constitutes a Mandelbrot-like family of polynomial-like maps, $Z(\omega)$ being conjugate to $z^2 - \lambda(L)$ in a vicinity of its Julia set, for L in a neighborhood of $[1, 3 + 2\sqrt{2}]$, say. A detailed discussion of the conjugacies involved, the dependence of λ on L and the reason such families often occur has been given by Douady and Hubbard.⁽¹⁹⁾

ACKNOWLEDGMENT

M. F. Barnsley was supported in part by NSF grant No. DMS-8401609.

E. R. Vrscay was supported in part by a 1984–85 Postdoctoral Fellowship from the Natural Sciences and Engineering Research Council of Canada.

We thank the Burroughs Corporation for supplying B-20 microcomputers on which some of the computations were made.

REFERENCES

1. E. Domany, S. Alexander, D. Bensimon, and L. P. Kadanoff, Solutions to the Schrödinger equation on some fractal lattices, preprint (1983).
2. R. Rammal, Spectrum of harmonic excitations on fractals, *J. Phys. (Paris)* **45**:191–206 (1984).
3. R. Rammal, On the nature of eigenstates on fractal structures, *Phys. Rev. B* **28**:4871–4874 (1983).
4. R. Rammal and G. Toulouse, Spectrum of the Schrödinger equation on a self-similar structure, *Phys. Rev. Lett.* **49**:1194–1197 (1982).
5. A. M. S. Tremblay and B. W. Southern, Scaling and density of states of fractal lattices from a generating function point of view, *J. Phys. Lett. (Paris)* **44**:L-843–L-852 (1983).
6. M. F. Barnsley, J. S. Geronimo, and A. N. Harrington, Condensed Julia sets, with an application to a fractal lattice model Hamiltonian, *Trans. Am. Math. Soc.* (1984) (to be published).
7. B. Derrida, L. De Seze, and C. Itzykson, Fractal structure of zeros in hierarchical models, *J. Stat. Phys.* **33**:559–570 (1983).
8. H. F. Olsen, *Dynamical Analogies*, 2nd ed. (Van Nostrand, New York, 1958).
9. P. Blanchard, Complex analytic dynamics on the Riemann sphere, *Bulletin A.M.S.* **11**:85–141 (1984).
10. M. P. Fatou, Sur les équations fonctionnelles, *Bull. Soc. Math. France* **47**:161–271 (1919); **48**:33–94, 208–314 (1919).
11. A. Denjoy, Sur l'itération des fonctions analytiques, *C. R. Acad. Sci.* **182**:255–257 (1926).
12. G. Valiron, Sur l'itération des fonctions holomorphes dans un demi-plan, *Bull. Sci. Math. (Ser. II)* **55**:105–128 (1931).
13. J. Wolff, Sur l'itération des fonctions holomorphes dans un région, et dont les valeurs appartiennent à cette région, *C. R. Acad. Sci. Paris* **182**:42, 43 (1926).
14. R. B. May, Simple mathematical models with very complicated dynamics, *Nature* **261**:459–467 (1976).
15. P. J. Myrberg, Sur l'itération des polynômes réels quadratiques, *J. Math. Pures Appl.* **41**:339–351 (1962).
16. J. Milnor and P. Thurston, On iterated maps of the interval, preprint.
17. B. Derrida, A. Gervois, and Y. Pomeau, Universal metric properties of bifurcations of endomorphisms, *J. Phys.* **A12**:269 (1969).
18. M. Feigenbaum, Quantitative universality for a class of nonlinear transformations, *J. Stat. Phys.* **19**:25–52 (1978).
19. A. Douady and J. Hubbard, On the dynamics of polynomial-like mappings, preprint (1984).

20. B. Mandelbrot, Fractal aspects of the iteration of $z \rightarrow \lambda z \cdot (1 - z)$, *Ann. N. Y. Acad. Sci.* **357**:249–259 (1980); On the quadratic mapping $z \rightarrow z^2 - \mu$ for complex μ and z : the fractal structure of its M set and scaling, *Physica D*, 224–239 (1983).
21. R. Bott and R. J. Duffin, Impedance synthesis without the use of transformers, *J. Appl. Phys.* **20**:816 (1949).
22. L. Weinberg, *Network Analysis and Synthesis* (McGraw-Hill, New York, 1962).
23. G. Kirchoff, Über die Auflösung der Gleichungen, auf welche man bei der Untersuchungen der Linearen Verteilung Galvanischer Ströme geführt wird, *Poggendorf Ann. Phys.* **72**:497–508 (1847).
24. H. Whitney, Nonseparable and planar graphs, *Trans. Am. Math. Soc.* **34**:339–362 (1932).
25. G. Julia, Mémoire sur l'itération des fonctions rationnelles, *J. Math. Pures Appl.* **4**:47–245 (1918).
26. B. Mandelbrot, *The Fractal Geometry of Nature* (W. H. Freeman, San Francisco, 1983).
27. H. Brolin, Invariant sets under iteration of rational functions, *Ark. Mat.* **6**:103–144 (1965).
28. D. Sullivan, Itération des fonctions analytiques complexes, *C. R. Acad. Sci.* **294**:301 (1982).
29. D. Sullivan, Quasi conformal homeomorphisms and dynamics III: Topological conjugacy classes of analytic endomorphisms, preprint (1983).
30. M. F. Barnsley, J. S. Geronimo, and A. N. Harrington, Orthogonal polynomials associated with invariant measures on Julia sets, *Bulletin A.M.S.* **7**:381–384 (1982).
31. D. Bessis and P. Moussa, Orthogonality properties of iterated polynomial mappings, *Commun. Math. Phys.* **88**:503–529 (1983).
32. M. F. Barnsley and A. N. Harrington, Moments of balanced measures on Julia sets, *Trans. Am. Math. Soc.* **284**:271–280 (1984).
33. A. Freire, A. Lopes, and R. Mané, An invariant measure for rational maps, preprint (1982).
34. M. J. Ljubich, Entropy properties of rational endomorphisms of the Riemann sphere, *Ergod. Th. Dyn. Syst.* **3**:351–383 (1983).
35. M. F. Barnsley and S. Demko, Iterated function systems and the global reconstruction of fractals, *Proc. R. Soc. London* (1984) (to be published).
36. P. Collet and J. Eckmann, *Iterated Maps on the Interval as Dynamical Systems* (Birkhauser, Boston, 1980).
37. M. F. Barnsley, J. S. Geronimo, and A. N. Harrington, Geometry and combinatorics of Julia sets for real quadratic maps, *J. Stat. Phys.* **37**:51–92 (1984).
38. D. Singer, Stable orbits and bifurcations of maps of the interval, *SIAM J. Appl. Math.* **35**:260 (1978).
39. O. Lanford III, A computer assisted proof of the Feigenbaum conjectures, *Bull. A.M.S.* **6**:427–434 (1982).